

# CrystaLatch™ 1x2 LiDAR Fiber Optic Switch

(PM, High Power)



(Protected by U.S. patents 7224860, 6757101, 6577430 and pending patents)

DATASHEET

BUY NOW

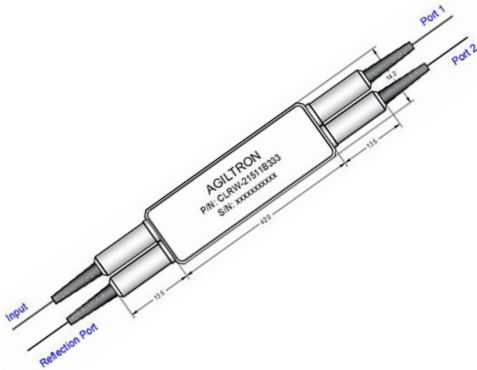

## Features

- Low Loss
- High Reliability
- Compact

## Applications

- Gain Control
- Power Equalizer

The CrystaLatch™ 1x2 Series LiDAR fiber optical switch is a non-mechanical device having advantageous features for LIDAR applications. It scans a probing laser beam among two output fiber ports with high power handling capability (5W CW) and redirects the reflecting light into a dedicated receiving signal fiber port. The patent pending design reduces more than 2dB system optical loss by eliminating the need to pass the reflected signal through an additional circulator or coupler. Moreover, it provides the receiving signal with over 60dB isolation from the probe laser beam via a proprietary patent pending configuration. The all solid state CL fiber optic switch further offers extremely high reliability in addition to low insertion loss, high extinction ratio, high channel isolation, and high repeatability. It is designed to meet the most demanding switching requirements of continuous operation without failure, longevity, operation under shock/vibration environment, with large temperature variations, and fast response time. The switches have been used in aerospace, out space, under sea, and outdoor applications.

Electronic driver is available for this series of switches.

The magneto-optical crystals used in the CL switches have no fatigue nor drift effect.

## Specifications

Parameter	Min	Typical	Max	Unit
Operation Wavelength <sup>[1]</sup>	1520	1550	1580	nm
	1295	1310	1325	nm
Insertion Loss <sup>[2]</sup>		1.2	1.6	dB
Receive Signal Isolation <sup>[3]</sup>	60	65		dB
Optical Switch Speed (Rise, Fall)		50	200	μs
Repetition Rate		2K		Hz
Channel Crosstalk	26	30		dB
Optical Power Handling			5 <sup>[4]</sup>	W
Durability	10 <sup>15</sup>			cycles
Switch type	Solid-State Latching			
Operating Temperature <sup>[5]</sup>	-5		+70	°C
Storage Temperature	-40		+85	°C
Fiber Type	PM1310, PM1550, or equivalent			

### Notes:

- [1]. Agiltron can achieve same SPEC at L band.
- [2]. Measured without connectors. We offer 5W connectors.
- [3]. Receiving signal isolation from probing laser, the value is for PM version
- [4]. Continuous operation.
- [5]. -40 to +85°C version is available. See "Ordering Information"

**Note:** The specifications provided are for general applications with a cost-effective approach. If you need to narrow or expand the tolerance, coverage, limit, or qualifications, please [click this link](#):

**Legal notices:** All product information is believed to be accurate and is subject to change without notice. Information contained herein shall legally bind Agiltron only if it is specifically incorporated into the terms and conditions of a sales agreement. Some specific combinations of options may not be available. The user assumes all risks and liability whatsoever in connection with the use of a product or its application.

Rev 07/19/24

© Photonwares Corporation

P +1 781-935-1200

E [sales@photonwares.com](mailto:sales@photonwares.com)

W [www.agiltron.com](http://www.agiltron.com)

Information contained herein is deemed to be reliable and accurate as of the issue date. Photonwares reserves the right to change the design or specifications at any time without notice. Agiltron is a registered trademark of Photonwares Corporation in the U.S. and other countries.

# CrystaLatch™ 1x2 LiDAR Fiber Optic Switch

(PM, High Power)



(Protected by U.S. patents 7224860, 6757101, 6577430 and pending patents)

## DATASHEET

### Mechanical Dimensions (Unit: mm)

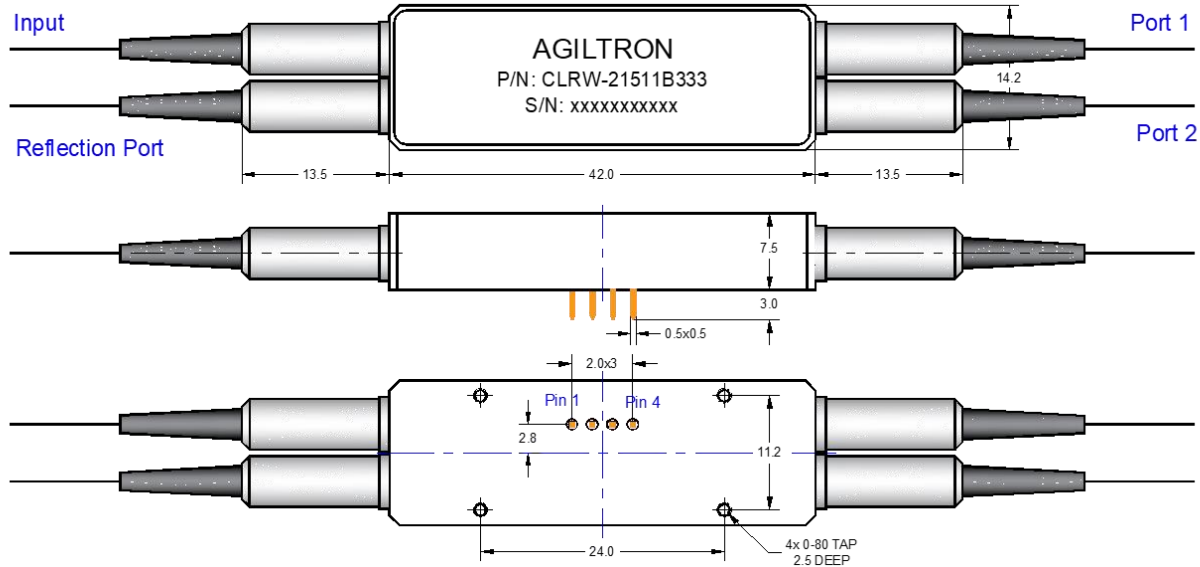

\*Product dimensions may change without notice. This is sometimes required for non-standard specifications.

### Electric Instruction – Coil Parameters and Driving Table

Each switching point is actuated by applying a polarity voltage pulse through a pair of PINS, and latched after pulse removed.

Parameter	Minimum	Typical	Maximum	Unit
Resistance (each Pin group)	15	18	22	Ω
Switch Voltage	2.25	2.5	2.75 [1]	V
Pulse Duration	0.2	0.3	0.5	ms

[1]. Over this value will damage the device.

### Electrical Driving Table

Optical Path	Pin Group 1		Pin Group 2	
	Pin 1	Pin 2	Pin 3	Pin 4
IN → P1 & P1 → R [1]	+ [2]	0	+	0
IN → P2 & P2 → R	0	+	0	+

[1]. IN: Input Port; P1: Port 1; R: Receive Port.

[2]. "+": 2.25~2.75V Pulse, Topical is 2.5V pulse

Driving kit with USB and/or RS232 or TTL interfaces is available. We provide GUI for USB and RS232 interface. Please contact sales for more information.

#### Note:

The driving voltage value is transient voltage with a full load. The driver circuitry needs to provide sufficient current (~300mA) during the switching. Inside the switch core is an electromagnet with a residual magnetic field. The residual magnetic field will be established when an electrical current flows in one direction through the coil for a sufficiently long period. The residual magnetic field latches the switch state even without applying a voltage (the current flow stopped). Flowing a current in the opposite direction for a sufficient time changes the switch stage by establishing a reversal magnetic field. The coil is forgiving to the driver unless one burns it by applying a higher voltage or a current for too long (day). The switch can also be operated at high repetition rates of kHz, where the residual magnetic field may not be fully established.

# CrystaLatch™ 1x2 LiDAR Fiber Optic Switch

(PM, High Power)



(Protected by U.S. patents 7224860, 6757101, 6577430 and pending patents)

## DATASHEET

### Typical Switching Response

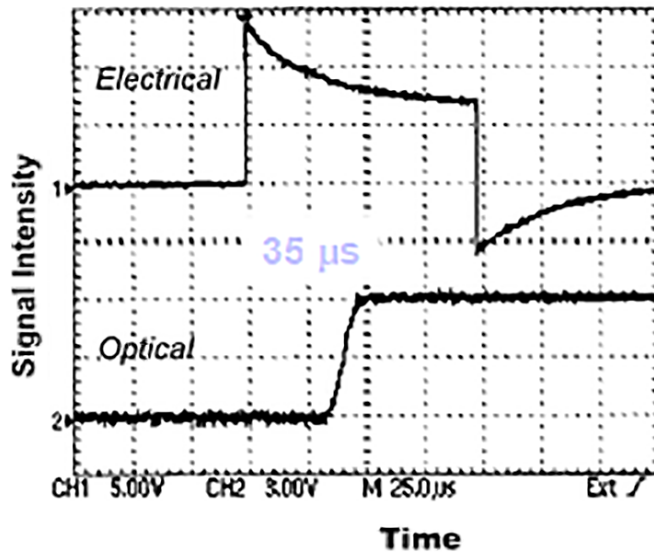

### Typical Loss Change of 1x2 vs Switching Numbers

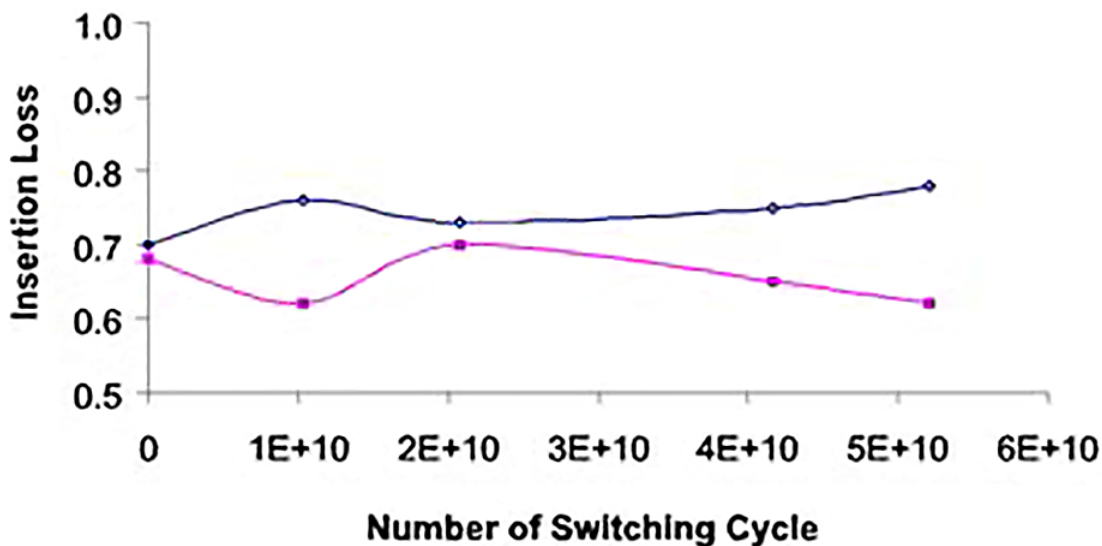

# CrystaLatch™ 1x2 LiDAR Fiber Optic Switch

(PM, High Power)



(Protected by U.S. patents 7224860, 6757101, 6577430 and pending patents)

## DATASHEET

### Optical Path Diagram

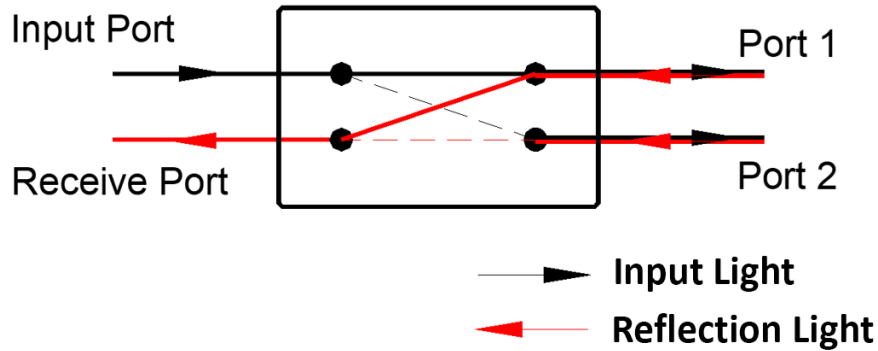

### Ordering Information

Prefix	Type	Stage	Wavelength	Power Handling	Package	Fiber Type	Fiber Cover	Fiber Length	Connector
CLRW-	1x2 = 2 Special = 0	Single Stage = 1	1310 = 3 1550 = 5 Special = 0	5 W = 2 Special = 0	Standard = 1 -40~+85°C = A -40~+70°C = B -20~+85°C = C Special = 0	PM1550 = B PM1310 = D Special = 0	Bare fiber = 1 900µm tube = 3 Special = 0	0.25m = 1 0.5m = 2 1.0m = 3 Special = 0	None = 1 FC/PC = 2 FC/APC = 3 SC/PC = 4 SC/APC = 5 ST/PC = 6 LC/PC = 7 Duplex LC/PC = 8 LC/APC = A LC/UPC = U Special = 0

#### Fiber Core Alignment

Note that the minimum attenuation for these devices depends on excellent core-to-core alignment when the connectors are mated. This is crucial for shorter wavelengths with smaller fiber core diameters that can increase the loss of many decibels above the specification if they are not perfectly aligned. Different vendors' connectors may not mate well with each other, especially for angled APC.

#### Fiber Cleanliness

Fibers with smaller core diameters (<5 µm) must be kept extremely clean, contamination at fiber-fiber interfaces, combined with the high optical power density, can lead to significant optical damage. This type of damage usually requires re-polishing or replacement of the connector.

#### Maximum Optical Input Power

Due to their small fiber core diameters for short wavelength and high photon energies, the damage thresholds for device is substantially reduced than the common 1550nm fiber. To avoid damage to the exposed fiber end faces and internal components, the optical input power should never exceed 20 mW for wavelengths shorter 650nm. We produce a special version to increase the how handling by expanding the core side at the fiber ends.

# CrystaLatch™ 1x2 LiDAR Fiber Optic Switch (PM, High Power)



(Protected by U.S. patents 7224860, 6757101, 6577430 and pending patents)

## DATASHEET

### Driver Design Example for 1x4

A recommended +5VDC powered driving circuit is provided. The resistor network R1~R8 is to suppress the driving signal's voltage level to meet the "switch voltage" requirements. In specific applications, users can use lower voltage to eliminate the R1~R8. The Q1~Q8 is the control signal from either a function generator or a microcontroller general purpose I/O. The Q1~Q8 switching speed must meet the specific MOSFET switching requirement and CL 1x4 Switch specific requirement. Usually, the control signal speed is  $\leq 2\text{kHz}$ .

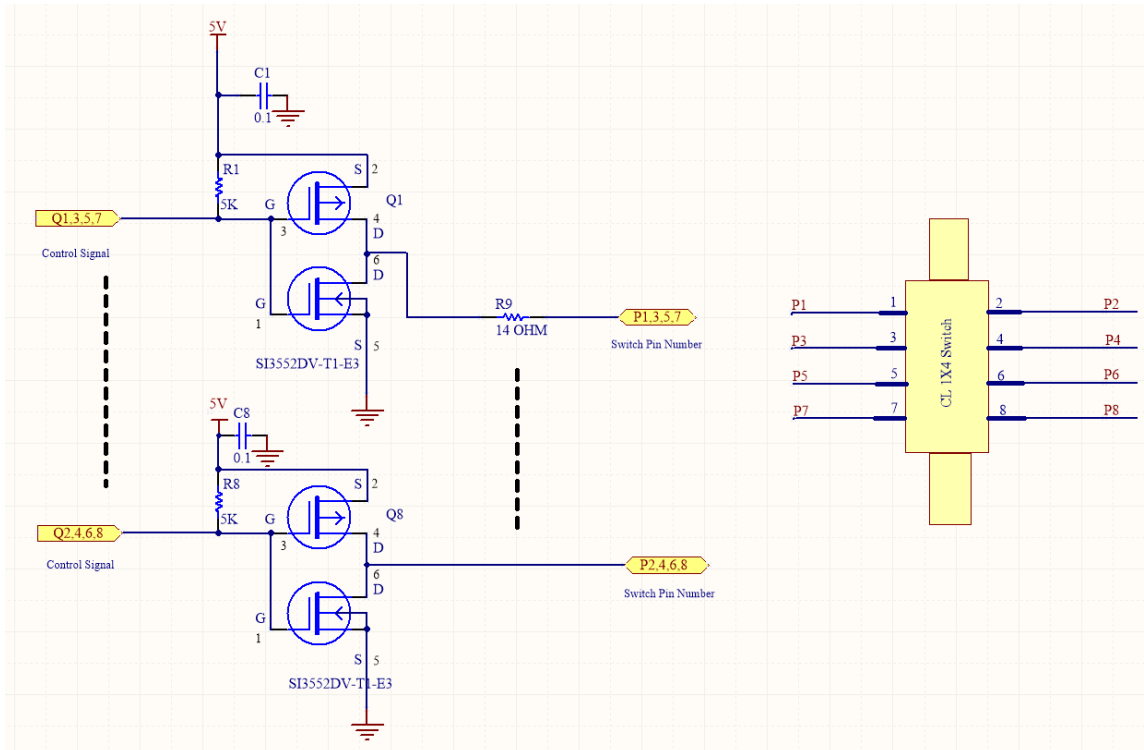

Usually, a clean power supply source will be sufficient. However, decoupling capacitors for the transistor supply rail are recommended depending on different applications. Minimum the current loop on the switching circuits will minimize the switching noise. For other layout recommendations, please refer to books or application notes from the IC manufacturer.